

1-1/4" & 1-1/2" DIAPHRAGM VALVE - STANDARD MODEL

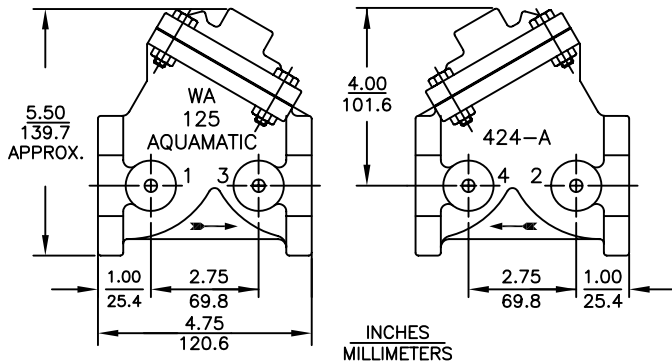

REPAIR PARTS KITS			
DESCRIPTION	PART NO.		
DIAPHRAGM & SEALS KIT CONSISTS OF ITEM NO'S 3,5,6,8,9,12,15,16,18	1070069 (424-RA)	1070082 (424-RAE)	1070094 (424-RAV)
	BUNA N INCLUDES DIAPHRAGM	E.P.D.M. INCLUDES DIAPHRAGM	FKM INCLUDES DIAPHRAGM
	1074222 (424-FB)	1074222 (424-FB)	1074224 (424-FV)
INT. PARTS KIT (NORM. OPEN) CONSISTS OF STANDARD ITEM NO'S 4,7,10,11(2),19	1070119 (424-RF)		
SEAT (ITEM NO. 2)	1074245 (424-MO)		

ASSEMBLY TOOLS	
DESCRIPTION	PART NO.
FOR INSTALLATION & REMOVAL OF SEAT (ITEM #2) (TOOL NOT SHOWN)	1074247 (424-MT)
FOR INSTALLATION & REMOVAL OF SHAFT GUIDE (ITEM #10) (TOOL NOT SHOWN)	1074227 (424-GT)

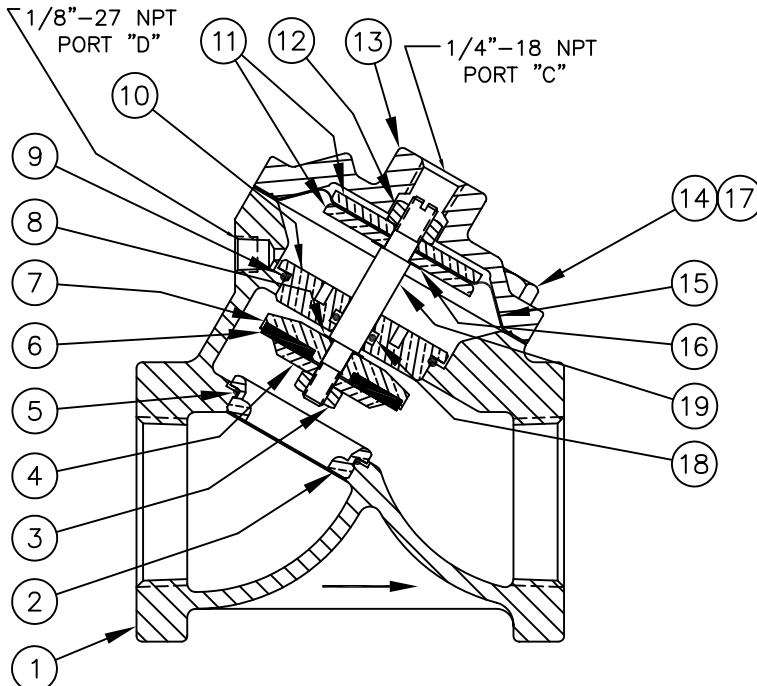

- NOTE:
1. AMERICAN NATIONAL STANDARD TAPER PIPE THREADS (NPT) PER ANSI B2.1-1968
 2. VALVES AVAILABLE WITH B.S.P. OR J.I.S. END CONNECTIONS.

1070023 (V42D-0000-00000) (1-1/4" NPT)
 1070025 (V42E-0000-00000) (1-1/2" NPT)
NORMALLY OPEN (STANDARD)

SEE REVERSE SIDE FOR
CONFIGURATION OPTIONS

NO.	DESCRIPTION		STD	PART NO.	QTY.
1	BODY	CAST IRON	1-1/4" NPT *	1074196 (424-A5)	1
			1-1/2" NPT *	1074199 (424-A6)	
	CAST BRASS	1-1/4" NPT	1074190 (424-AB5)	1-1/2" NPT	
2	SEAT (REQ'S ASSY TOOL)	BRASS	*	1074245 (424-MO)	1
3	HEX LOCK NUT	(1/4-28)	*	1071650 (NUS-0010)	1
4	DISC PLATE	BRASS	*	1074237 (424-K)	1
		STN. STL.		1074238 (424-KS)	
5	O-RING	BUNA N	*	1071678 (ORB-028)	1
		E.P.D.M.		1071723 (ORE-028)	
		VITON		1071793 (ORV-028)	
6	DISC	BUNA N	*	1074232 (424-J)	1
		E.P.D.M.		1074233 (424-JE)	
		FKM		1074236 (424-JV)	
		HYCAR		1074234 (424-JH)	
7	DISC HOLDER	BRASS	*	1074229 (424-H)	1
		STN. STL.		1074231 (424-HS)	
8	GASKET	COPPER	*	1073948 (200-GG)	1
		LEAD		1073949 (200-GGL)	
9	O-RING	BUNA N	*	1071695 (ORB-132)	1
		E.P.D.M.		1071734 (ORE-132)	
		FKM		1071806 (ORV-132)	
10	SHAFT GUIDE (REQ'S ASSY TOOL)	BRASS	*	1074225 (424-GG0)	1
		STN. STL.		1074226 (424-GGS)	
11	DIAPHRAGM PLATE	BRASS	*	1074220 (424-D)	2
		STN. STL.		1074221 (424-DS)	
12	HEX LOCK NUT	(5/16-24)	*	1071651 (NUS-0013)	1
13	CAP	CAST IRON	*	1074202 (424-C)	1
		CAST BRASS		1074206 (424-CB)	
14	HEX SCREW	PLATED STEEL	*	1072399 (SCZ-0007)	4
		STN. STL.		1072392 (SCS-0156)	
15	DIAPHRAGM	BUNA N	*	1074222 (424-FB)	1
		FKM		1074224 (424-FV)	
16	GASKET	COPPER	*	1074252 (424-R)	1
		LEAD		1074263 (424-RL)	
17	HEX NUT	PLATED STEEL		1071656 (NUZ-0008)	4
		STN. STL.		1071649 (NUS-0007)	
18	O-RING	BUNA N	*	1071689 (ORB-110TC)	1
		E.P.D.M.		1071726 (ORE-110TC)	
		FKM		1071798 (ORV-110)	
19	SHAFT (NORMALLY OPEN)		*	1074239 (424-L)	1

FORM NO. 1077614

C	NUMBER CONVERSION	1588	MSM	27NOV02	
REV	DESCRIPTION	ECO	DWN	DATE	APVD



OSMONICS
 ROCKFORD OPERATIONS
 2412 GRANT AVENUE, ROCKFORD, IL 61103-3991 (815) 964-9421
 WWW.OSMONICS.COM

SERIES 424 DIAPHRAGM VALVE
1-1/4" & 1-1/2" N.P.T.

SCALE	DRAWN	DATE	DWG. NO.
N/A	JWB	30APR01	1084019

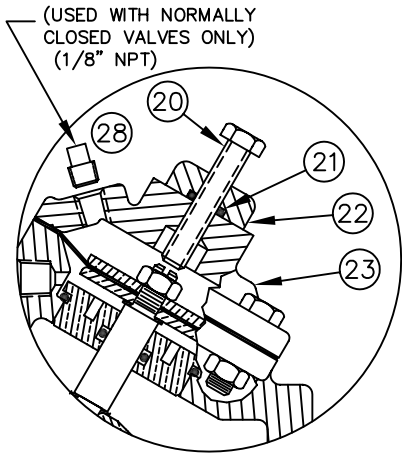

1072720 (V42D-0010-00000) (1-1/4" NPT)
1070028 (V42E-0010-00000) (1-1/2" NPT)

LIMIT STOP

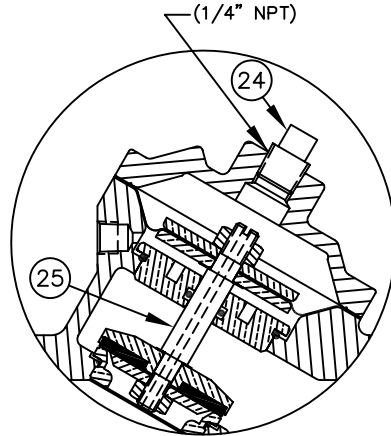

1072723 (V42D-0030-00000) (1-1/4" NPT)
1070026 (V42E-0030-00000) (1-1/2" NPT)

NORMALLY CLOSED

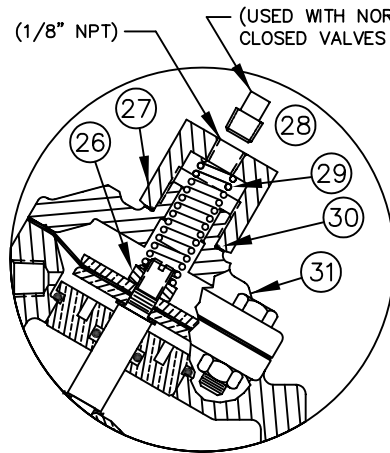

1072716 (V42D-0002-00000) (1-1/4" NPT)
1072792 (V42E-0002-00000) (1-1/2" NPT)

SPRING ASSIST CLOSED

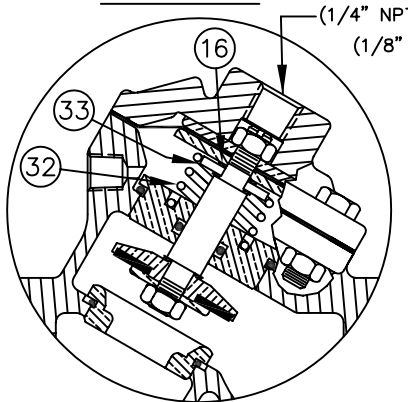

1072715 (V42D-0001-00000) (1-1/4" NPT)
1070027 (V42E-0001-00000) (1-1/2" NPT)

SPRING ASSIST OPEN

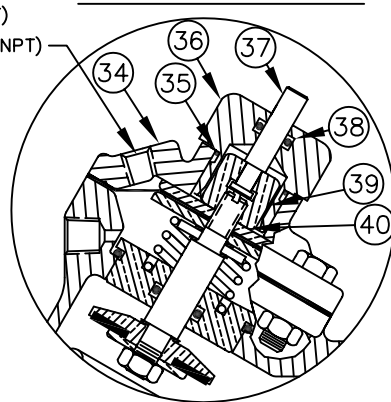

1072722 (V42D-0021-00000) (1-1/4" NPT)
1072804 (V42E-0021-00000) (1-1/2" NPT)

POSITION INDICATOR

CONVERSION KITS	
DESCRIPTION	PART NO.
CONVERSION KIT (LIMIT STOP) CONSISTS OF STANDARD ITEM NO'S 20,21,22,23	1074243 (424-LSC)
CONVERSION KIT (SPRING ASSIST CLOSED) CONSISTS OF STANDARD ITEM NO'S 26 THRU 31	1074266 (424-SCC)
CONVERSION KIT (SPRING ASSIST OPEN) CONSISTS OF STANDARD ITEM NO'S 10,16,32,33	1074269 (424-SOC)
CONVERSION KIT (POSITION INDICATOR) CONSISTS OF STANDARD ITEM NO'S 34 THRU 40	1074250 (424-PIC)

REPAIR PARTS KITS	
DESCRIPTION	PART NO.
INT. PARTS KIT (LIMIT STOP) CONSISTS OF STANDARD ITEM NO'S 20,21,22	1074242 (424-LS)
INT. PARTS KIT (NORM. CLOSED) CONSISTS OF STANDARD ITEM NO'S 4,7,10,11(2),25	1070130 (424-RG)
INT. PARTS KIT (SPRING ASSIST CLOSED) CONSISTS OF STANDARD ITEM NO'S 26,29,30	1074265 (424-SC)
INT. PARTS KIT (SPRING ASSIST OPEN) CONSISTS OF STANDARD ITEM NO'S 16,32,33	1074268 (424-SO)
INT. PARTS KIT (POSITION INDICATOR) CONSISTS OF STD ITEM NO'S 35 THRU 40	1074249 (424-PI)

NO.	DESCRIPTION	STD	PART NO.	QTY.
LIMIT STOP MODEL				
20	SCREW	*	1072362 (SCS-0031)	1
21	O-RING	*	1071668 (ORB-012)	1
22	NUT	*	1077534 (400-H)	1
23	CAP		CAST IRON * 1074210 (424-CCC)	1
			CAST BRASS 1074213 (424-CCCB)	
NORMALLY CLOSED MODEL				
24	PIPE PLUG (1/4" N.P.T.)		PLATED STEEL * 1071918 (PLZ-0008)	1
			BRASS 1071904 (PLB-0009)	
			STN. STL. 1071915 (PLS-0001)	
25	SHAFT (NORMALLY CLOSED)	*	1074241 (424-LL)	1
SPRING ASSIST CLOSED MODEL				
26	CENTERING NUT	*	1074276 (424-X)	1
27	RETAINER NUT		BRASS * 1074274 (424-TT)	1
			STN. STL. 1074275 (424-TTS)	
28	PIPE PLUG (1/8" N.P.T.)		PLATED STEEL * 1071917 (PLZ-0005)	1
			BRASS 1071903 (PLB-0007)	
			STN. STL. 1071916 (PLS-0002)	
29	SPRING	*	1074270 (424-SS)	1
30	O-RING	*	1071674 (ORB-020)	1
31	CAP		CAST IRON * 1074208 (424-CC)	1
			CAST BRASS 1074209 (424-CCB)	
SPRING ASSIST OPEN MODEL				
16	GASKET		COPPER * 1074252 (424-R)	1
			LEAD 1074263 (424-RL)	
32	SPRING	*	1074264 (424-S)	1
33	CENTERING WASHER		BRASS * 1074382 (426-HA)	1
			STN. STL. 1074384 (426-HAS)	
POSITION INDICATOR MODEL				
34	CAP		CAST IRON * 1074217 (424-CF)	1
			CAST BRASS 1074218 (424-CFB)	
35	O-RING	*	1071692 (ORB-116)	1
36	SHAFT GUIDE BUSHING	*	1074121 (421-GF)	1
37	INDICATOR SHAFT	*	1074251 (424-PM)	1
38	O-RING	*	1071688 (ORB-108TC)	1
39	TOP NUT	*	1074272 (424-TB)	1
40	LOCKWASHER	*	1073590 (WAS-0007)	1

NOTE:

1. SPRING ASSIST CLOSED MODEL CANNOT BE COMBINED WITH LIMIT STOP MODEL.
2. VALVES AVAILABLE WITH B.S.P. OR J.I.S. END CONNECTIONS.

SEE REVERSE SIDE FOR STANDARD NORMALLY OPEN MODEL

FORM NO. 1077614

C	NUMBER	CONVERSION	1588	MSM	27NOV02
REV	DESCRIPTION	ECO	DWN	DATE	APVD
 ROCKFORD OPERATIONS 2412 GRANT AVENUE, ROCKFORD, IL 61103-3991 (815) 964-9421 WWW.OSMONICS.COM					
SERIES 424 DIAPHRAGM VALVE 1-1/4" & 1-1/2" N.P.T.					
SCALE	DRAWN	DATE	DWG. NO.		
N/A	JWB	30APR01	1084019		