

REPAIR PARTS KITS			
DESCRIPTION	PART NO.		
DIAPHRAGM & SEALS KIT CONSISTS OF ITEM NO'S 3(2),5,6,8(2),9,14,16	1070071 (426-RA)	1070084 (426-RAE)	1070096 (426-RAV)
	BUNA N INCLUDES DIAPHRAGM 1074374 (426-FB)	E.P.D.M. INCLUDES DIAPHRAGM 1074374 (426-FB)	FKM INCLUDES DIAPHRAGM 1074376 (426-FV)
	1070121 (426-RF)		
INT. PARTS KIT (NORM. OPEN) CONSISTS OF STANDARD ITEM NO'S 4,7,10,11(2),17,18	1070121 (426-RF)		
SEAT (ITEM NO. 2)	1074409 (426-MO)		

ASSEMBLY TOOLS	
DESCRIPTION	PART NO.
FOR INSTALLATION & REMOVAL OF SEAT (ITEM #2) (TOOL NOT SHOWN)	1074411 (426-MT)
FOR INSTALLATION & REMOVAL OF SHAFT GUIDE (ITEM #10) (TOOL NOT SHOWN)	1-1/4" HEX (E) SOCKET

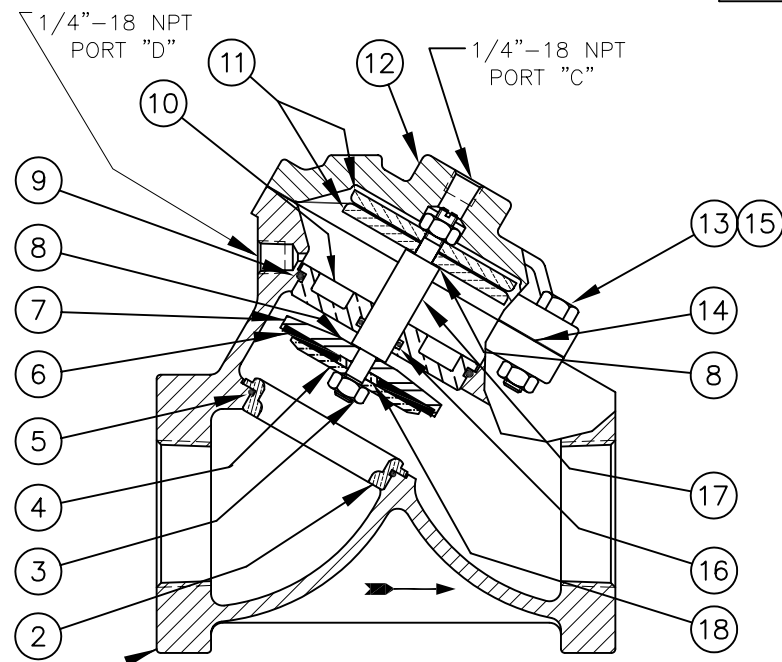

1070041 (V42G-0000-00000) (2" NPT)
1070042 (V42H-0000-00000) (2-1/2" NPT)

NORMALLY OPEN (STANDARD)

- NOTE:
1. AMERICAN NATIONAL STANDARD TAPER PIPE THREADS (NPT) PER ANSI B2.1-1968
 2. VALVES AVAILABLE WITH B.S.P. OR J.I.S. END CONNECTIONS.

NO.	DESCRIPTION	STD	PART NO.	QTY.
1	BODY	CAST IRON	2" NPT * 1074343 (426-AB)	1
		CAST BRASS	2-1/2" NPT * 1081559 (426-A10)	
2	SEAT (REQ'S ASSY TOOL)	BRASS	1074338 (426-AB8)	1
		STN. STL.	1074335 (426-AB10)	
3	HEX LOCK NUT (5/16-24)	*	1074409 (426-MO)	2
4	DISC PLATE	BRASS	1074408 (426-MAVO)	1
		STN. STL.	1071651 (NUS-0013)	
5	O-RING	BUNA N	* 1074395 (426-K)	1
		E.P.D.M.	* 1074398 (426-KS)	
		FKM	* 1071696 (ORB-144)	
6	DISC	BUNA N	* 1071737 (ORE-144)	1
		E.P.D.M.	1074394 (426-JV)	
		FKM	1071809 (ORV-144)	
		HYCAR	1074389 (426-J)	
7	DISC HOLDER	BRASS	* 1074391 (426-JE)	1
		STN. STL.	1074394 (426-JV)	
8	GASKET	COPPER	* 1074381 (426-H)	1
		LEAD	1074386 (426-HS)	
9	O-RING	BUNA N	* 1074252 (424-R)	1
		E.P.D.M.	1074263 (424-RL)	
		FKM	1071706 (ORB-233)	
10	SHAFT GUIDE (REQ'S ASSY TOOL)	BRASS	* 1071754 (ORE-233)	1
		STN. STL.	1071826 (ORV-233)	
11	DIAPHRAGM PLATE	BRASS	* 1074379 (426-GO)	2
		STN. STL.	1074370 (426-D)	
12	CAP	CAST IRON	* 1074371 (426-DA)	1
		CAST BRASS	1074348 (426-CB)	
13	HEX SCREW	PLATED STEEL	* 1072401 (SCZ-0015)	6
		STN. STL.	1072358 (SCS-0016)	
14	DIAPHRAGM	BUNA N	* 1074374 (426-FB)	1
		FKM	1074376 (426-FV)	
15	HEX NUT	PLATED STEEL	* 1071657 (NUZ-0011)	6
		STN. STL.	1071655 (NUS-0035)	
16	O-RING	BUNA N	* 1071691 (ORB-114TC)	1
		E.P.D.M.	1071729 (ORE-114TC)	
		FKM	1071800 (ORV-114)	
17	SHAFT (NORMALLY OPEN)	*	1074400 (426-L)	1
18	DISC SPACER	BRASS	* 1074382 (426-HA)	1
		STN. STL.	1074384 (426-HAS)	

SEE REVERSE SIDE FOR
CONFIGURATION OPTIONS

FORM NO. 1077616

E	WAS 1 3/16" HEX SOCKET	NONE	MSM	15MAR04
REV	DESCRIPTION	ECO	DWN	DATE APVD



OSMONICS
ROCKFORD OPERATIONS
2412 GRANT AVENUE, ROCKFORD, IL 61103-3991 (815) 964-9421
WWW.OSMONICS.COM

SERIES 426 DIAPHRAGM VALVE
2" & 2-1/2" N.P.T.

SCALE N/A	DRAWN JWB	DATE 02MAY01	DWG. NO. 1084021
--------------	--------------	-----------------	---------------------

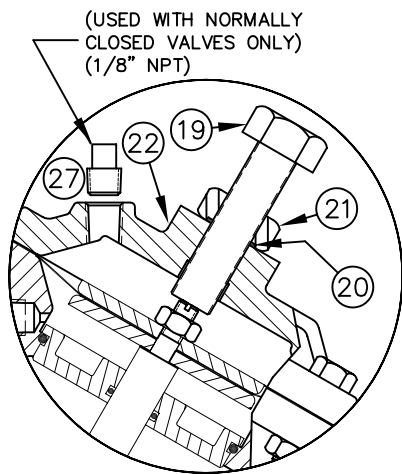

1072939 (V42G-0010-00000) (2" NPT)
 1072998 (V42H-0010-00000) (2-1/2" NPT)

LIMIT STOP

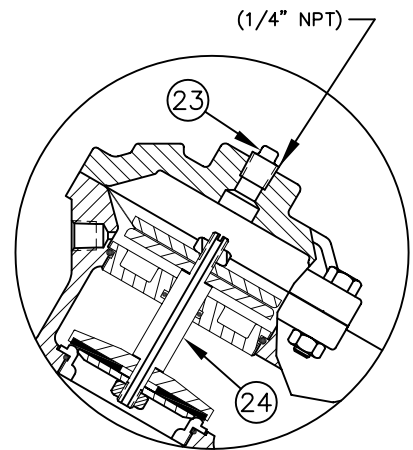

1072945 (V42G-0030-00000) (2" NPT)
 1073002 (V42H-0030-00000) (2-1/2" NPT)

NORMALLY CLOSED

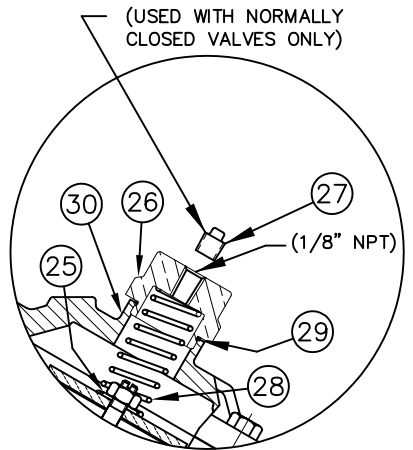

1072935 (V42G-0002-00000) (2" NPT)
 1072996 (V42H-0002-00000) (2-1/2" NPT)

SPRING ASSIST CLOSED

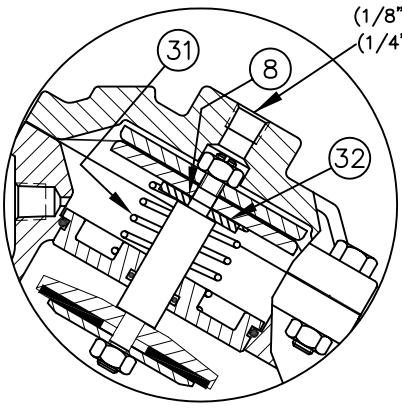

1072932 (V42G-0001-00000) (2" NPT)
 1072994 (V42H-0001-00000) (2-1/2" NPT)

SPRING ASSIST OPEN

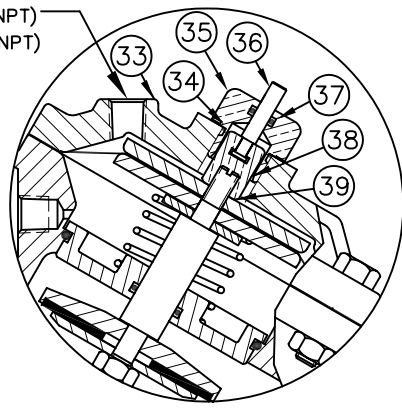

1072943 (V42G-0021-00000) (2" NPT)
 1073001 (V42H-0021-00000) (2-1/2" NPT)

POSITION INDICATOR

CONVERSION KITS	
DESCRIPTION	PART NO.
CONVERSION KIT (LIMIT STOP) CONSISTS OF STANDARD ITEM NO'S 19,20,21,22	1074406 (426-LSC)
CONVERSION KIT (SPRING ASSIST CLOSED) CONSISTS OF STANDARD ITEM NO'S 25 THRU 30	1074426 (426-SCC)
CONVERSION KIT (SPRING ASSIST OPEN) CONSISTS OF STANDARD ITEM NO'S 8,31,32	1074427 (426-SO)
CONVERSION KIT (POSITION INDICATOR) CONSISTS OF STANDARD ITEM NO'S 33 THRU 39	1074414 (426-PIC)

REPAIR PARTS KITS	
DESCRIPTION	PART NO.
INT. PARTS KIT (LIMIT STOP) CONSISTS OF STANDARD ITEM NO'S 19,20,21	1074405 (426-LS)
INT. PARTS KIT (NORM. CLOSED) CONSISTS OF STANDARD ITEM NO'S 4,7,10,11(2),18,24	1070132 (426-RC)
INT. PARTS KIT (SPRING ASSIST CLOSED) CONSISTS OF STANDARD ITEM NO'S 25,28,29	1074425 (426-SC)
INT. PARTS KIT (SPRING ASSIST OPEN) CONSISTS OF STANDARD ITEM NO'S 8,31,32	1074427 (426-SO)
INT. PARTS KIT (POSITION INDICATOR) CONSISTS OF STD ITEM NO'S 34 THRU 39	1074413 (426-PI)

NO.	DESCRIPTION	STD	PART NO.	QTY.
LIMIT STOP MODEL				
19	SCREW	*	1072364 (SCS-0042)	1
20	O-RING	*	1071690 (ORB-112)	1
21	NUT	*	1074434 (426-U)	1
22	CAP	CAST IRON	1074354 (426-CCC)	1
		CAST BRASS	1074357 (426-CCCB)	
NORMALLY CLOSED MODEL				
23	PIPE PLUG (1/4" N.P.T.)	PLATED STEEL	1071918 (PLZ-0008)	1
		BRASS	1071904 (PLB-0009)	
		STN. STL.	1071915 (PLS-0001)	
24	SHAFT (NORMALLY CLOSED)	*	1074402 (426-LL)	1
SPRING ASSIST CLOSED MODEL				
25	CENTERING WASHER	BRASS	1074083 (421-AH)	1
		STN. STL.	1074084 (421-AHS)	
26	RETAINER NUT	BRASS	1074430 (426-TT)	1
		STN. STL.	1074433 (426-TTS)	
27	PIPE PLUG (1/8" N.P.T.)	PLATED STEEL	1071917 (PLZ-0005)	1
		BRASS	1071903 (PLB-0007)	
		STN. STL.	1071916 (PLS-0002)	
28	SPRING	*	1078688	1
29	O-RING	*	1071677 (ORB-025)	1
30	CAP	CAST IRON	1074352 (426-CC)	1
		CAST BRASS	1074353 (426-CCB)	

SPRING ASSIST OPEN MODEL				
8	GASKET	COPPER	1074252 (424-R)	1
		LEAD	1074263 (424-RL)	
31	SPRING	*	1078692	1
32	CENTERING WASHER	BRASS	1074436 (426-V)	1
		STN. STL.	1074437 (426-VS)	

POSITION INDICATOR MODEL				
33	CAP	CAST IRON	1074360 (426-CF)	1
		CAST BRASS	1074364 (426-CFB)	
34	O-RING	*	1071692 (ORB-116)	1
35	SHAFT GUIDE BUSHING	*	1074121 (421-GF)	1
36	INDICATOR SHAFT	*	1074325 (425-PM)	1
37	O-RING	*	1071688 (ORB-108TC)	1
38	TOP NUT	*	1074332 (425-TB)	1
39	LOCKWASHER	*	1073590 (WAS-0007)	1

SEE REVERSE SIDE FOR
 STANDARD NORMALLY OPEN MODEL
 FORM NO. 1077616

E	SEE REVERSE SIDE	NONE	MSM	15MAR04
REV	DESCRIPTION	ECO	DWN	DATE APVD



OSMONICS
 ROCKFORD OPERATIONS
 2412 GRANT AVENUE, ROCKFORD, IL 61103-3991 (815) 964-9421
 WWW.OSMONICS.COM

SERIES 426 DIAPHRAGM VALVE
2" & 2-1/2" N.P.T.

SCALE N/A	DRAWN JWB	DATE 02MAY01	DWG. NO. 1084021
--------------	--------------	-----------------	---------------------